

Wiring Diagrams and Electrical Specifications

CAUTION! Before connecting any device at the installation site, verify input voltage and current using a multimeter. Many power supplies and transformers operate at higher levels than listed. Any input voltage exceeding 10% of the solenoid rating may cause severe damage to the unit and will void the warranty.

Strikes requiring 12VDC have black leads; 24VDC have blue leads. (Note that the leads are protected with a plastic sleeve which may or may not match the lead colors.)

GENERAL INFORMATION:

- All HES, Inc. electric strikes are equipped with either a 12VDC or 24VDC solenoid, which provides silent operation. These units are not designed for direct AC operation.
- Operation with an AC power supply can be accommodated through the incorporation of the Model 2001 Bridge Rectifier. This full wave bridge rectifier simply plugs between the connector provided from the Electric Strike and the power supply.
- Other input voltages can be accommodated by using the Model 2005 Smart-Pac™ II Line Controller. This unit also plugs directly into the circuit and allows additional control of optional features. The Smart-Pac™ II includes a built-in full wave bridge rectifier.
- The Model 2006P Buzzer provides audible indication of strike operation (ordered separately).

- The Model 2009P LED provides visual indication of the strike operation (ordered separately).
- All of the above features may be used together, although the Model 2001 bridge rectifier is not required with the Model 2005 Smart-Pac™ II.

OPERATION:

- FAIL SECURE:** When power is supplied to the strike the plunger is retracted and the unit is unlocked. If power fails, the strike is locked and the door is secured.
- FAIL SAFE:** When power is supplied to the strike, the plunger is extended and the unit is locked. If power fails, the strike is unlocked, and door is safe (unlocked) for exit.
- Field reversible - fail secure/fail safe

TYPICAL PLUG-IN DETAILS:

Standard Buzzer Installations

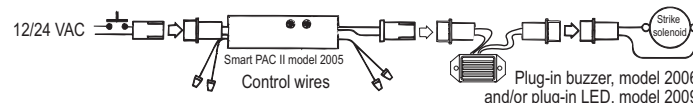
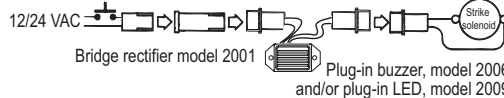
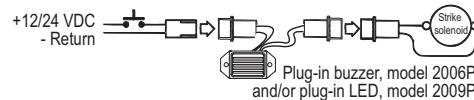

7000/7400 LATCHBOLT MONITOR:

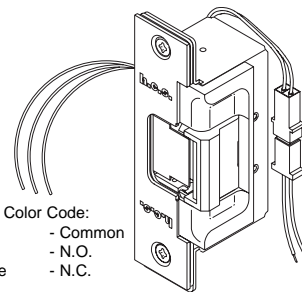

Wiring Color Code:
 White - Common
 Green - N.O.
 Orange - N.C.



- U.L. listed for burglary resistance, category 1034
- Patent #4,017,107 #4,026,589 #4,595,220 #4,626,010 #4,669,766 #5,484,180

ELECTRICAL RATINGS FOR SOLENOID	Continuous Duty	
	24 VDC	12 VDC
Resistance in Ohms	96	26.7
Watts Seated	6	5.4
Amps Seated	.25	.45

Solenoids are rated at +/- 10% indicated value

MINIMUM WIRE GAUGE REQUIREMENTS	Solenoid Voltage	
	24 VDC	12 VDC
200 feet or less	18 gauge	18 gauge
200 - 300 feet	18 gauge	16 gauge
300 - 400 feet	16 gauge	14 gauge

THREE YEAR LIMITED WARRANTY

For any questions regarding this information, call our Technical Service Line at 800-626-7590

2005 SMART-Pac™ II In-line power controller

The SMART-Pac™ II is a small in-line power controller that enables the electric strike to operate with a variety of voltages, from 12 to 32 volts, AC or DC, while utilizing only one solenoid. The SMART-Pac™ II provides electronic regulated current for continuous duty operation without the normal heat build up. It includes an adjustable minimum activation timer which can be set from 2 to 8 sec-

onds, or deactivated. The timer can be activated in both fail secure and fail safe operations. This device has been designed with on board safety features, including an in-line fuse to protect the strike and an M.O.V. to protect the host system from any possible reverse current surges. By including the 2005 with the HES Electric Strike, it truly becomes a SMART-STRIKE™.

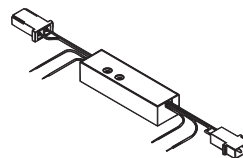

7000/7400 SERIES ELECTRIC STRIKES

INSTALLATION INSTRUCTIONS • Please read carefully before attempting installation.

DIMENSIONS:
 INCH
 [MM]

hes
 Hanchett Entry Systems, Inc.
 22630 N. 17th Ave.
 Phoenix, AZ 85027
 www.hesinnovations.com
 Technical Service Dept. Helpline 800-626-7590 623-582-4626

701 - OPTION FACEPLATE

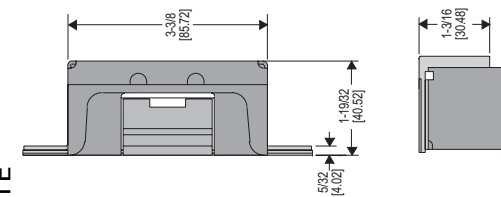

702 - OPTION FACEPLATE

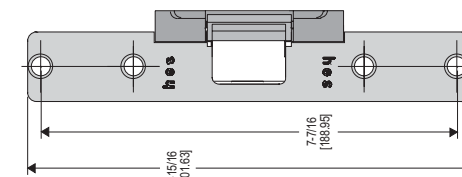

783 - OPTION/7483 MODEL FACEPLATE

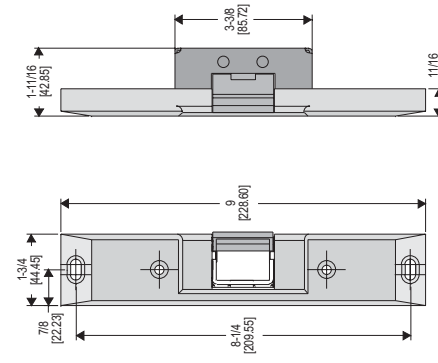

786 - OPTION/7486 MODEL FACEPLATE

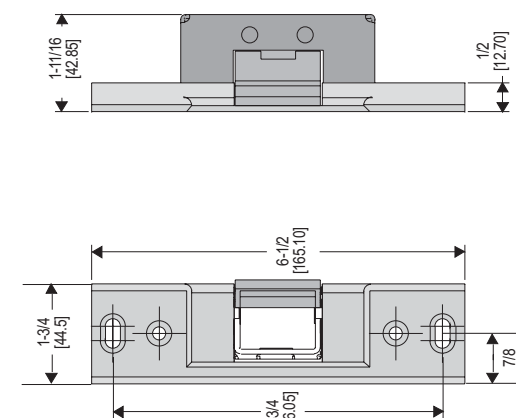

789 - OPTION/7489 MODEL FACEPLATE

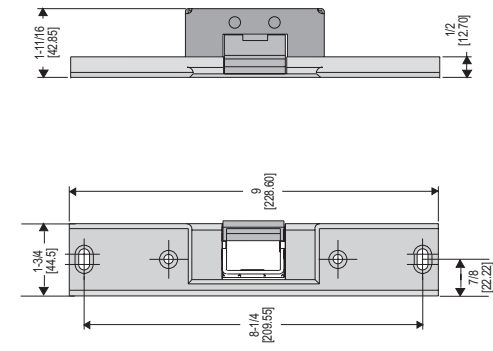

FIELD REVERSIBLE

CONVERTING BETWEEN FAIL SAFE AND FAIL SECURE

- Note how the mounting screw, washers, and cotter pin hold the solenoid in position.
- Straighten the two legs and remove the cotter pin from the solenoid linkage.
- Remove the mounting screws and washers.
- Carefully pull the solenoid assembly out of the keeper module.
- Turn the solenoid assembly end-over-end, and reinsert it back into the keeper module.
- Re-install the mounting screw and washers (at the opposite end from which they were originally installed). Make certain that the "D" washer is positioned firmly into the solenoid slot as noted on the illustration.
- Replace the cotter pin, spreading the two legs, securing the solenoid linkage.

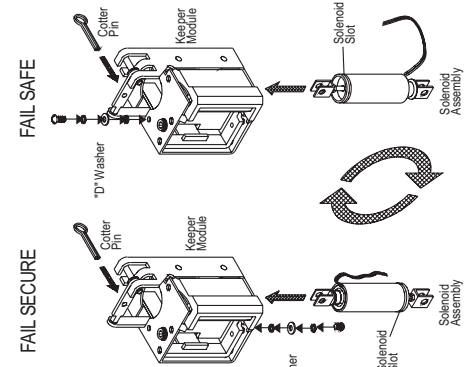

7000/7400 Series Installation Instructions

INSTALLATION INSTRUCTIONS

1. Prepare door jamb per appropriate template detail.
2. Install mounting tabs using #10 x 32 screws (when applicable). Do not tighten.
3. Unplug wire pigtail from electric strike.
4. Connect wires coming from the low voltage power source (see wiring diagrams and electrical specifications) to the electric strike pigtail.
5. Re-connect the pigtail to the electric strike.
6. Install electric strike and option face plate to jamb, using 12-24 machine screws or wood screws provided in the option package.
7. Secure 10 x 32 screws holding mounting tabs (when applicable).

NOTE 1: It is important to allow enough space behind the electric strike in the jamb cut-out to allow for the wires to exit the unit. Bunching the wires inside the electric strike body may cause the unit to not operate properly.

NOTE 2: HES offers a universal Metal Template Kit to simplify the installation procedure. Order model 154-MTK.

FIG. 1 DOOR JAMB DESCRIPTION

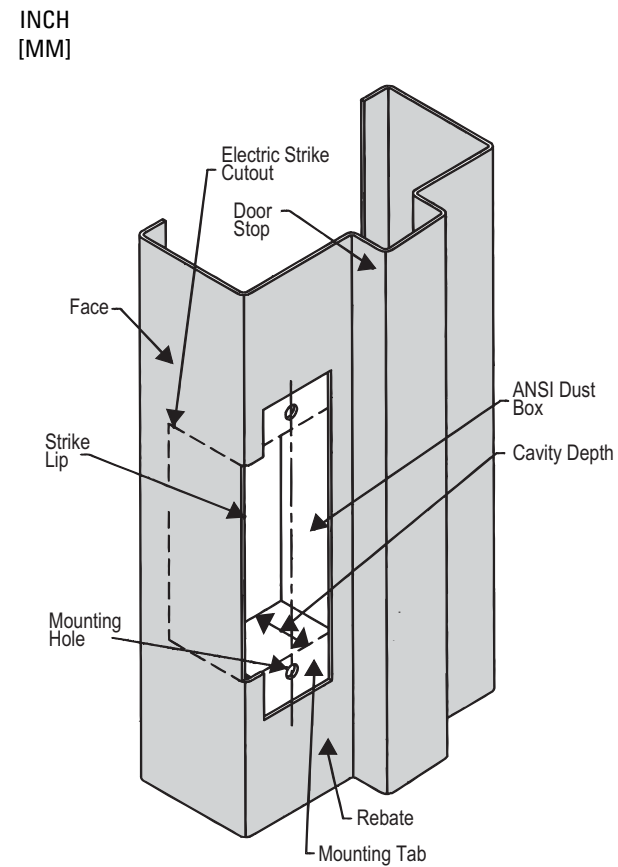

7000/7400 Series Installation Instructions

783 OPTION
FACEPLATE: 9 x 1-3/4 x 11/16

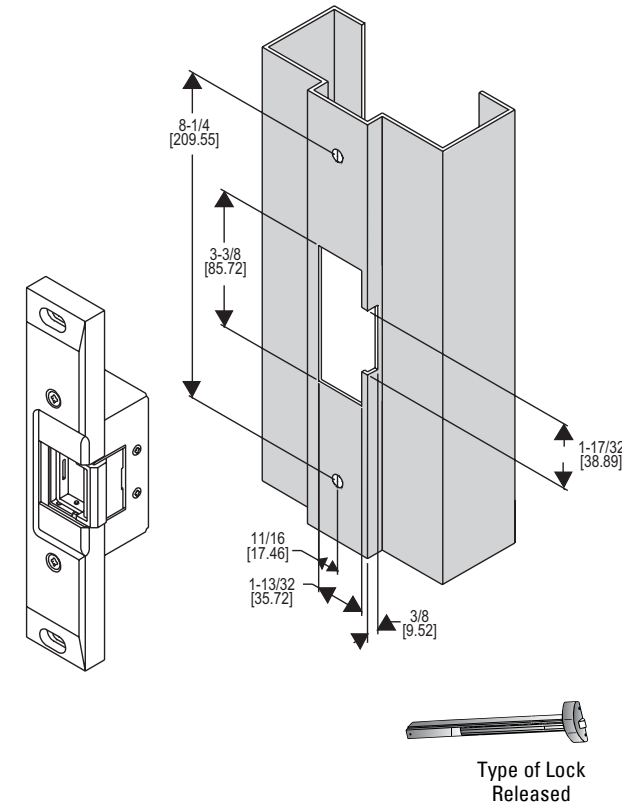

786 OPTION
FACEPLATE: 6-1/2 X 1-3/4 X 1/2"

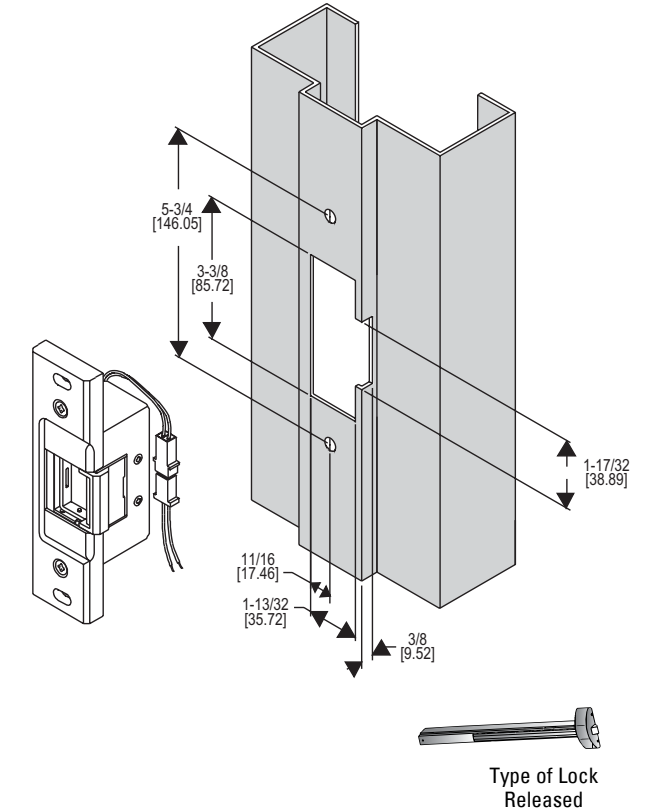

FIG. 2 701 OPTION
FACEPLATE: 4-7/8 X 1-1/4

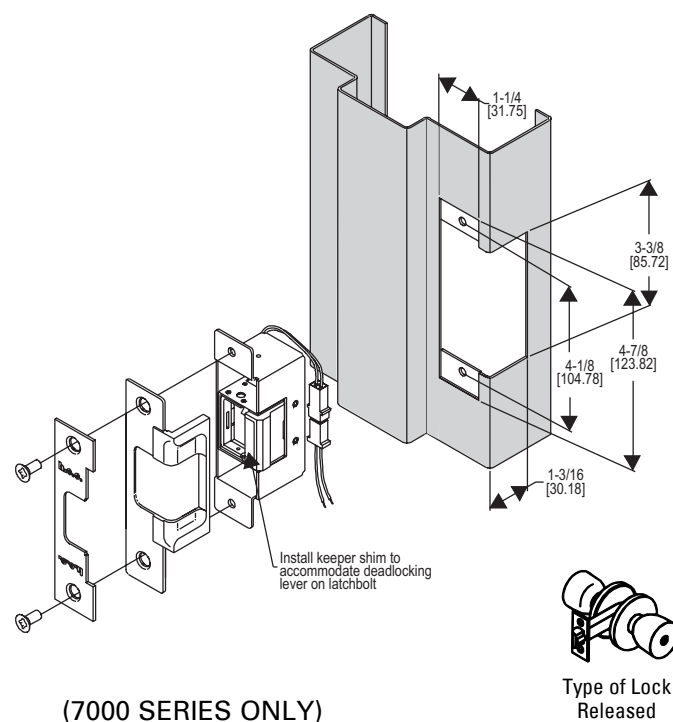
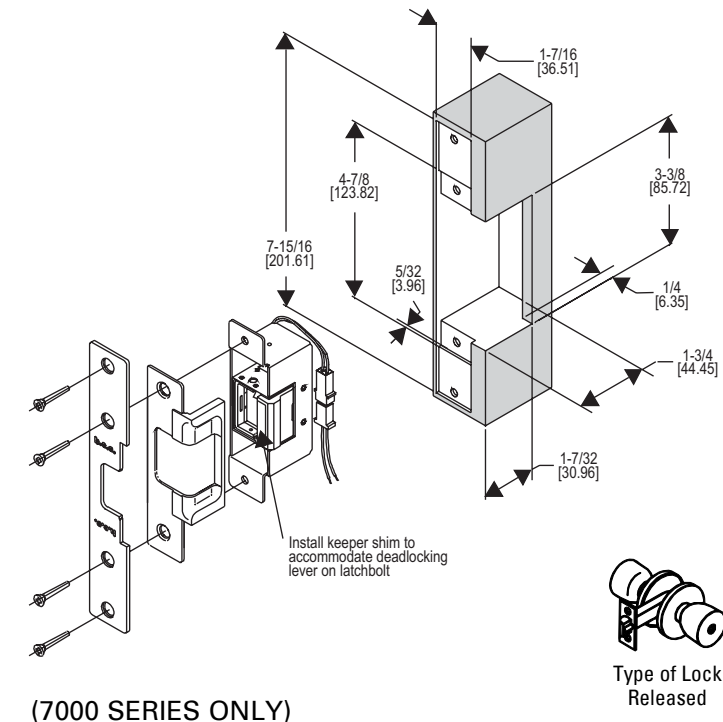
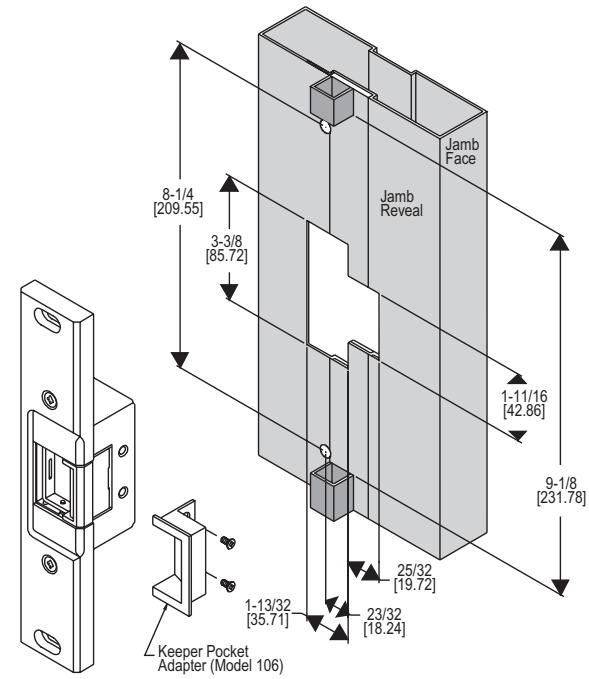

FIG. 3 702 OPTION
FACEPLATE: 7-15/16 X 1-7/16



789 OPTION
FACEPLATE: 9 x 1-3/4 x 1/2"



THREE YEAR LIMITED WARRANTY
FOR ANY QUESTIONS REGARDING THIS INFORMATION,
CALL OUR TECHNICAL SERVICE LINE AT 800-626-7590